



TR450



TR550

OWNER'S MANUAL

Table of Contents

Product Registration.....	2
Important Safety Instructions.....	3
Important Electrical Information.....	4
Important Operation Instructions.....	5
Assembly instructions.....	6
Operation of Your New Treadmill.....	10
General Maintenance.....	17
Manufacturer’s Limited Warranty.....	21



**CONGRATULATIONS ON YOUR
NEW TREADMILL AND WELCOME
TO THE XTERRA FAMILY!**

Thank you for your purchase of this quality treadmill from Xterra. Your new treadmill has been manufactured by one of the leading fitness manufacturers in the world and is backed by one of the most comprehensive warranties available. Xterra will do all we can to make your ownership experience as pleasant as possible for many years to come.

If you have questions, or if parts are missing or damaged, or you require customer service, call (870) 935-1107. Please have your Model number and serial number handy when you call.

Please take a moment at this time to record below the name of the store, their telephone number, and the date of purchase for easy contact in the future. We appreciate your confidence in Xterra and we will always remember that you are the reason that we are in business. Please complete and mail your registration card today and enjoy your new treadmill.

Yours in Health,
The folks at Xterra Fitness

Name of Dealer _____
Telephone Number of Dealer _____
Purchase Date _____

Product Registration

RECORD YOUR SERIAL NUMBER

Please record the Serial Number of this fitness product in the space provided below.

Serial Number _____

REGISTER YOUR PURCHASE

The self-addressed product registration card must be completed in full and returned to Xterra fitness, or visit: www.xterrafitness.com to register online.

TR450/ TR550_Ver.A

Important Safety Instructions

WARNING - Read all instructions before using this appliance.

DANGER - To reduce the risk of electric shock disconnect your Xterra treadmill from the electrical outlet prior to cleaning and/or service work.

WARNING - To reduce the risk of burns, fire, electric shock, or injury to persons, install the treadmill on a flat level surface with access to a 120-volt, 15-amp grounded outlet.

DO NOT USE AN EXTENSION CORD UNLESS IT IS 14AWG OR BETTER, WITH ONLY ONE OUTLET ON THE END. The treadmill should be the only appliance in the circuit in which it is connected. **DO NOT ATTEMPT TO DISABLE THE GROUNDED PLUG BY USING IMPROPER ADAPTERS, OR IN ANY WAY MODIFY THE CORD SET.** A serious shock or fire hazard may result along with computer malfunctions. See Grounding Instructions, page 3.

- Do not operate treadmill on deeply padded, plush or shag carpet. Damage to both carpet and treadmill may result.
- Do not block the rear of the treadmill. Provide a minimum of 3 1/2 feet clearance between the rear of the treadmill and any fixed object.
- Keep children away from the treadmill. There are obvious pinch points and other caution areas that can cause harm.
- Keep hands away from all moving parts.
- Never operate the treadmill if it has a damaged cord or plug. If the treadmill is not working properly, call your dealer.
- Keep the cord away from heated surfaces.
- Do not operate where aerosol spray products are being used or where oxygen is being administered. Sparks from the motor may ignite a highly gaseous environment.
- Never drop or insert any object into any openings.
- Do not use outdoors.
- To disconnect, turn all controls to the off position, remove tether cord, then remove the plug from the outlet.
- Do not attempt to use your treadmill for any purpose other than for the purpose it is intended.
- The pulse sensors are not medical devices. Various factors, including the user's movement, may affect the accuracy of heart rate readings. The pulse sensors are intended only as exercise aids in determining heart rate trends in general.
- Use handrails provided; they are for your safety.
- Wear proper shoes. High heels, dress shoes, sandals or bare feet are not suitable for use on your treadmill. Quality athletic shoes are recommended to avoid leg fatigue.

**Remove tether cord after use to prevent unauthorized treadmill operation.
SAVE THESE INSTRUCTIONS - THINK SAFETY!**

Important Electrical Information

WARNING!

■ **NEVER** use a ground fault circuit interrupt (GFCI) wall outlet with this treadmill. Large switching currents of the drive motor will trip GFCI type outlets, as any appliance with a large motor will. Route the power cord away from any moving part of the treadmill including the elevation mechanism and transport wheels.

■ **NEVER** remove any cover without first disconnecting AC power.

■ If voltage varies by ten percent (10%) or more, the performance of your treadmill may be affected. **Such conditions are not covered under your warranty.** If you suspect the voltage is low, contact your local power company or a licensed electrician for proper testing.

■ **NEVER** expose this treadmill to rain or moisture. This product is **NOT** designed for use outdoors, near a pool or spa, or in any other high humidity environment. The operating temperature specification is 40 to 120 degrees Fahrenheit and humidity limit is 95%, non-condensing (no water drops forming on surfaces).

Grounding Instructions

This product must be grounded. If the treadmill should malfunction or breakdown, proper grounding provides a path of least resistance for electric current, reducing the risk of electric shock. This product is equipped with a cord having an equipment-grounding plug. The plug must be plugged into an appropriate outlet that is properly installed and grounded in accordance with all local codes and ordinances.

DANGER - Improper connection of the equipment-grounding conductor can result in a risk of electric shock. Check with a qualified electrician or serviceman if you are in doubt as to whether the product is properly grounded. Do not modify the plug provided with the product if it will not fit the outlet; have a proper outlet installed by a qualified electrician.

This product is for use on a nominal 120-volt circuit, and has a grounding plug that looks like the plug illustrated below. A temporary adapter that looks like the adapter illustrated below may be used to connect this plug to a 2-pole receptacle as shown below if a properly grounded outlet is not available. The temporary adapter should be used only until a properly grounded outlet, (below) can be installed by a qualified electrician. The green colored rigid ear-lug, or the like, extending from the adapter, must be connected to a permanent ground such as a properly grounded outlet box cover. Whenever the adapter is used, it must be held in place by a metal screw.

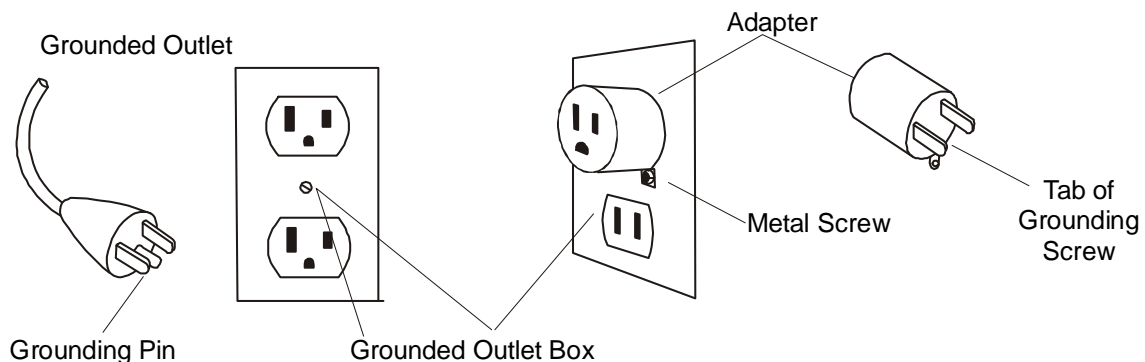

Important Operation Instructions

- NEVER operate this treadmill without reading and completely understanding the results of any operational change you request from the computer.
- Understand that changes in speed and incline do not occur immediately. Set your desired speed on the computer console and release the adjustment key. The computer will obey the command gradually.
- NEVER use your treadmill during an electrical storm. Surges may occur in your household power supply that could damage treadmill components.
- Use caution while participating in other activities while walking on your treadmill; such as watching television, reading, etc. These distractions may cause you to lose balance or stray from walking in the center of the belt, which may result in serious injury.
- NEVER mount or dismount the treadmill while the belt is moving. Xterra treadmills start with at a very low speed and it is unnecessary to straddle the belt during start up. Simply standing on the belt during slow acceleration is proper after you have learned to operate the unit.
- ALWAYS hold on to a handrail or hand bar while making control changes (incline, speed, etc.).

Safety Tether Cord

A safety tether cord is provided with this unit. It is a simple magnetic design that should be used at all times. It is for your safety should you fall or move too far back on the tread-belt. Pulling this safety tether cord will stop tread-belt movement.

To Use:

1. Place the magnet into position on the round portion of the console control head. Your treadmill will not start and operate without this. Removing the magnet also secures the treadmill from unauthorized use.
2. Fasten the plastic clip onto your clothing securely to assure good holding power. **Note:** The magnet has strong enough power to minimize accidental, unexpected stopping. The clip should be attached securely to make certain it does not come off. Be familiar with its function and limitations. The treadmill will stop, depending on speed, with a one to two step coast anytime the magnet is pulled off the console.

Assembly Instructions for TR250 and TR350

ASSEMBLY PACK CHECK LIST

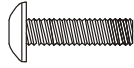

#111 - M5 x 15mm
Phillips Head Screw (8pcs)

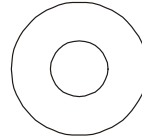

#95 - 5/16" x 19mm
Curved Washer (4pcs)

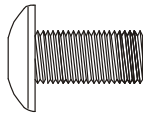

#94 - 5/16" x 15mm
Button Head Socket Bolt (14pcs)

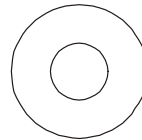

#110 - 5/16" x 19mm
Flat Washer (10pcs)

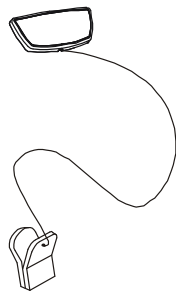

#102 - Safety Key (1pc)

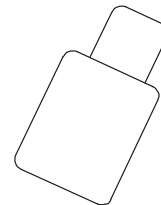

#93 - Lubricant (1pc)

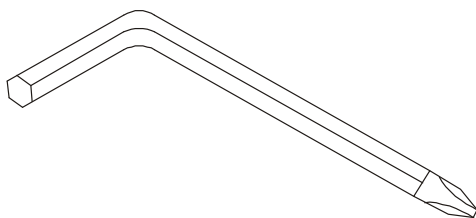

#97 - Combination M5 Allen Wrench
& Phillips Head Screw Driver (1pc)

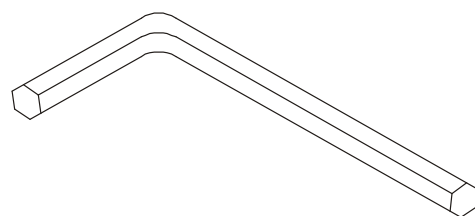

#98 - M6 Allen Wrench (1pc)

STEP 1

Remove all the parts from the carton and lay the main base frame on a flat level surface.

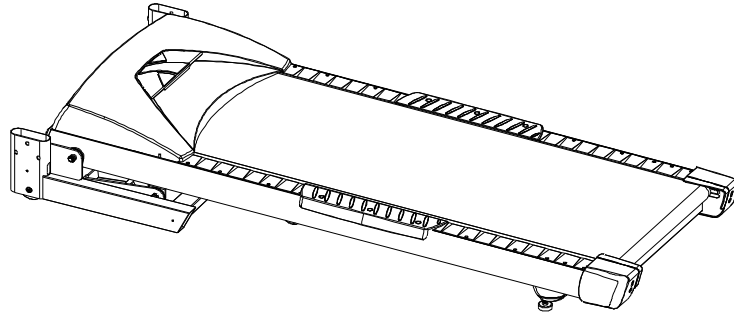

STEP 2

Feed the cable from the base frame (38) through the right side upright tube (5) and slide the tube into the base frame tube. **Be careful not to pinch the wire harness.** Install the left upright tube (4) and just hand tighten for now all eight 5/16" x 1/2" bolts (94) and the six 5/16" flat washers (110) for the side bolts and two 5/16" curved washers (95) for the front bolts. Tighten all eight bolts as tight as possible.

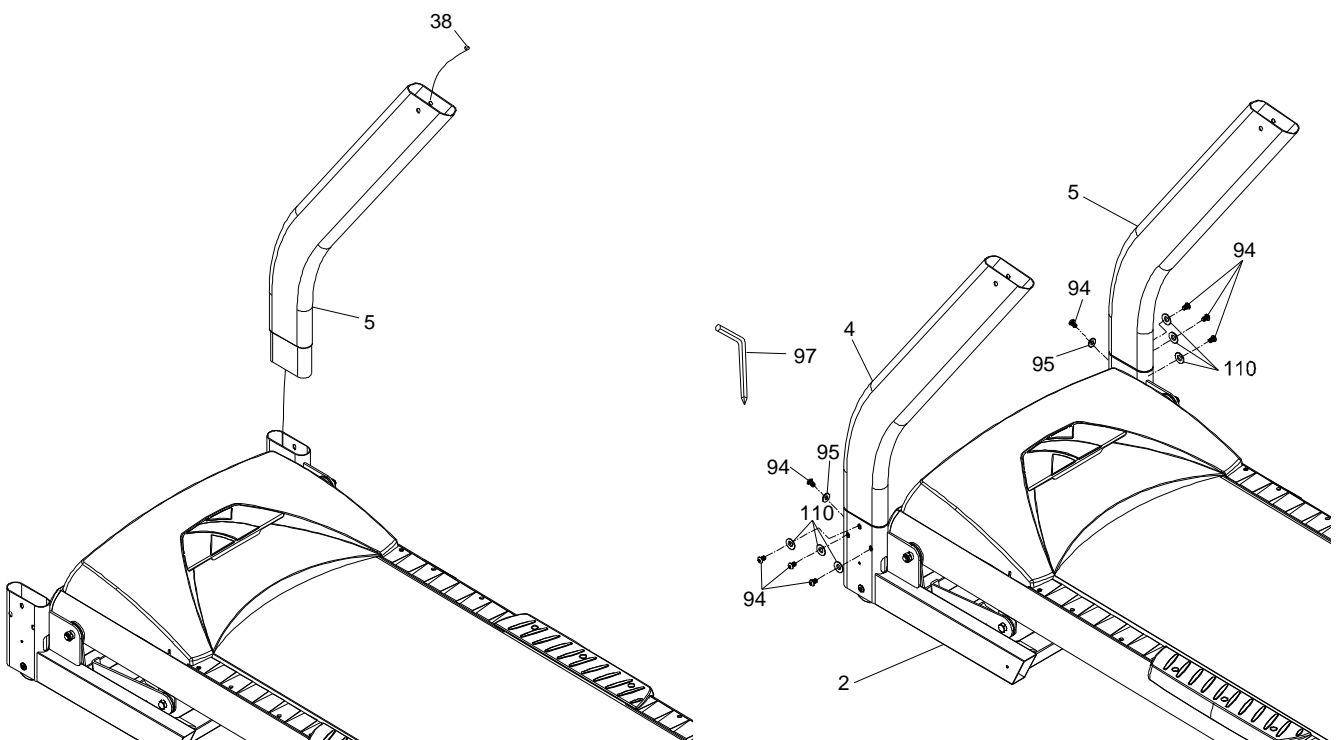

STEP 3

This step is easier if you have someone else helping to hold the console mounting frame while you connect the wire. Connect the computer cable (38) to the mating connector (36) of the console.

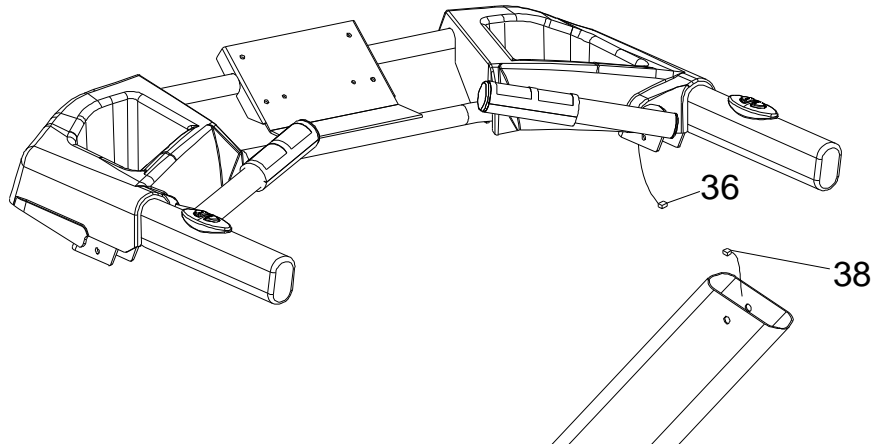

STEP 4

Secure the console with six 5/16" bolts (94) and 5/16" flat washers (110).

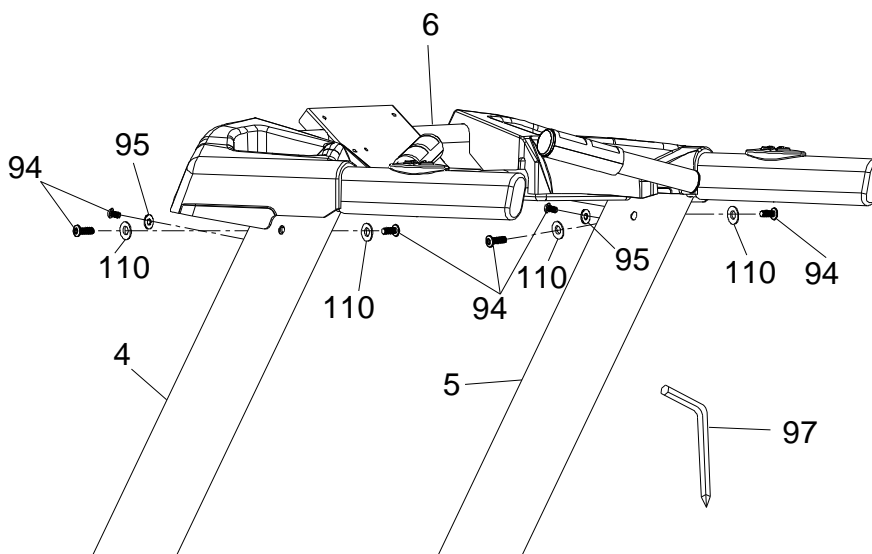

STEP 5

Connect all six connectors to the mating connectors on the back of the console. There are two 3-pin connectors that are color coded, make sure to plug them into the correct place. There are two 2-pin connectors that can be plugged into either mating connector on the console. Secure the console with four M5 X 15mm screws (111).

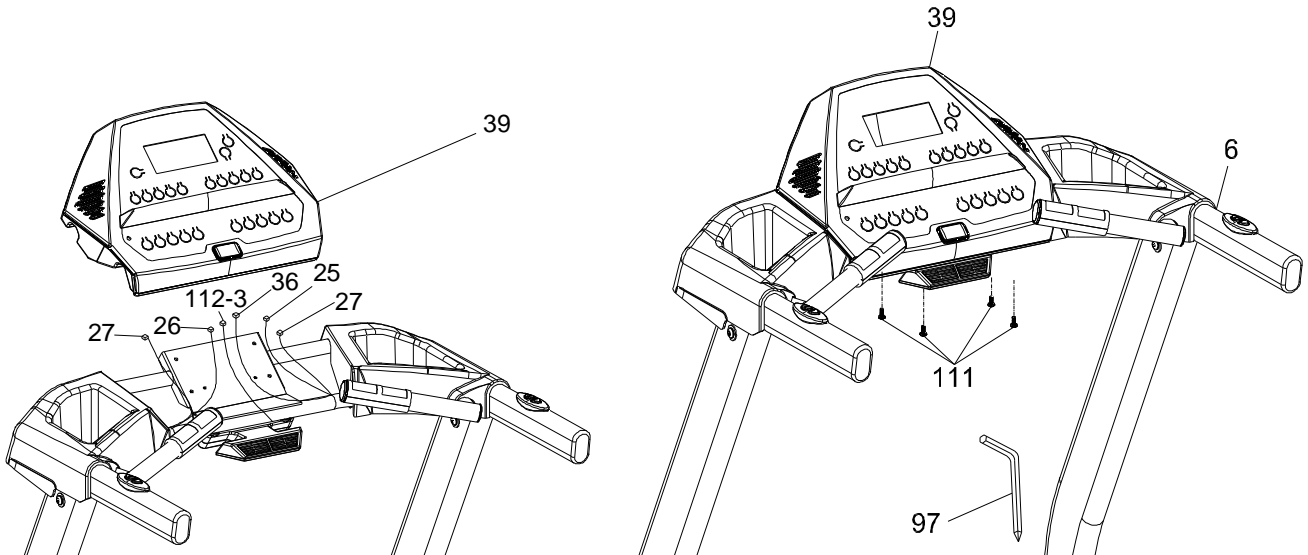

STEP 6

Attach the left (44) and right (43) covers to the upright base frame with four M5 X 15mm screws (111).

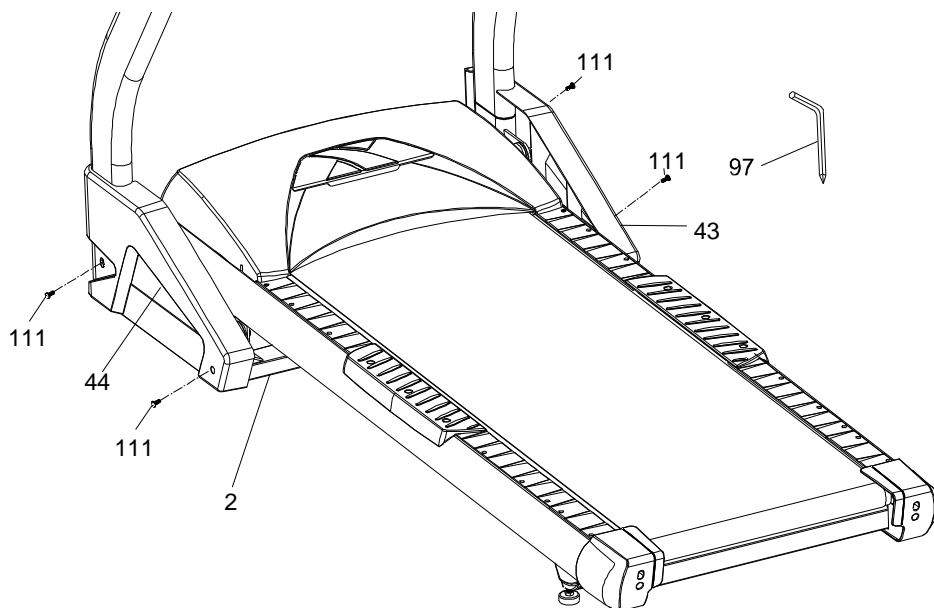

Operation of your new Treadmill



Getting started:

Power the treadmill on by plugging it into an appropriate wall outlet, then turn on the power switch located at the front of the treadmill below the motor hood. Ensure that the safety key is installed, as the treadmill will not operate without it.

When the power is turned on, a message will scroll across the dot matrix showing the current software version. Then the **Time** and **Distance** windows will display Odometer readings for a short time, **Time** window will show how many hours the treadmill has been in use and the **Distance** window will show how many miles (or Kilometers if the treadmill is set to metric readings) the treadmill has gone. The treadmill will then enter idle mode, which is the starting point for operation.

Quick-Start Operation:

STEP 1: Attach the **Safety** key to enable the display (**if not already on**).

STEP 2: Press the **Start** key to **begin belt movement**. Then adjust to the desired speed using the **Fast / Slow** keys (console or handgrip). You may also use the rapid speed keys 2 through 10 to adjust the speed.

STEP 3: To slow tread-belt press and hold the **Slow** key (console or handgrip) to the desired speed. You may also press the rapid speed adjust keys, 2 through 10.

STEP 4: To stop the tread-belt press **Stop** key or pull away **Safety** key.

Pause/Stop/Reset Feature:

STEP 1: When the treadmill is running the pause feature may be utilized by pressing the red **Stop** key once. This will slowly decelerate the tread-belt to a stop. The incline will go to zero percent. The Time, Distance and Calorie readings will hold while the unit is in the pause mode. After 5 minutes the display will reset and return to the start up screen.

STEP 2: To resume your exercise, when in Pause mode, press the **Start** key. The speed and incline will return to their previous settings.

| Pause is executed when the **Stop** button is pressed once. If the **Stop** key is pressed a second time, the program will end and a workout summary will be displayed. If the **Stop** button is pressed a third time, the console will return to the idle mode (start up) screen. If the **Stop** button is held down for more than 3 seconds the console will reset.

Incline Feature:

- | Incline may be adjusted anytime after belt movement.
- | Press and hold the **Adjust UP/DOWN** keys (console or handgrip) to achieve desired level of effort. You may also choose a more rapid increase / decrease by selecting desired key, 2 through 10, on left hand side of console (incline).
- | The display will indicate incline position as adjustments are made.

Dot Matrix Center Display (Program Operation):

Twenty rows of dots (8 high) indicate each segment of a workout. The dots are only to show an approximate level (speed/incline) of effort. They do not necessarily indicate a specific value - only an approximate percent to compare levels of intensity. In operation the Speed / Incline dot matrix window will build a profile "picture" as values are changed during a workout.

When the Speed indicator - which is above dot matrix - is lit the Dot matrix displays the Speed profile and when the Incline indicator is lit the Dot Matrix displays the Incline profile.

You may change the Dot Matrix profile view that you desired by pressing the DISPLAY button. After scrolling through the three profiles which include incline, speed and incline+ speed profile, by pressing the DISPLAY button, the Dot matrix will automatically scroll through the three displays showing each one for five seconds.

1/4 mile Track:

The 1/4-mile track will be displayed around the dot matrix window. The flashing dot indicates your progress. Once the 1/4-mile is complete this feature will begin again. The number of completed laps is displayed in the Laps window.

Pulse Grip Feature:

The Pulse (Heart Rate) console window will display your current heart rate in beats per minute during the workout. You must use both stainless steel sensors on the front cross bar to display your pulse or the wireless chest strap. Pulse value displays anytime the upper display is receiving a Pulse signal.

Calorie Display:

Displays the cumulative calories burned at any given time during your workout.

Note: This is only a rough guide used for comparison of different exercise sessions, which cannot be used for medical purposes.

To Turn Treadmill Off:

(1) Display will automatically turn off (go to sleep) after 30 minutes (no key operations). The treadmill will draw very little current in sleep mode (about as much as your television when it is turned off).

(2) Remove tether cord.

(3) Turn of the main switch on the front of the treadmill, below the motor cover.

Programmable Features

The TR450 has five factory preset programs, two user defined programs, two heart rate control programs and one Manual program.

The TR550 has nine factory preset programs, two user defined programs, two heart rate control programs and one Manual program.

Each preset program has a maximum speed level that is displayed when a desired workout is chosen. The maximum speed that the particular program will achieve will be displayed in the Speed window.

To Select a Program:

STEP 1: Press the **PROGRAM** key to select desired program. Press enter to select the program. The display will prompt you through the programming or you can just press Start to begin the program with default values.

STEP 2: If enter was pressed, the **Time** window will display with the default value of 20 minutes. You may use any of the up/down, fast/slow keys to adjust the time. After adjusting, or to accept the default value, press enter. (Note: You may press start at any time during the programming to start the program.)

STEP 3: The **Calorie** window will now be displaying a value, which is your **Body Weight**. Entering the correct body weight will affect the calorie count. Use the Up/Down keys, Fast/Slow to adjust, then press enter.

A note about the **Calorie** display: No exercise machine can give you an exact calorie count because there are too many factors which determine exact calorie burn for a particular person. Even if someone is the exact same body weight, age and height, their calorie burn may be very different than yours. The **Calorie** display is to be used as a reference only to monitor improvement from workout to workout.

STEP 4: The **Calorie** window will display the preset top speed of the selected program. Use the Up/Down, Fast/Slow keys to adjust, then press enter. Each program has various speed changes throughout; this allows you to limit the highest speed the program can reach.

STEP 5: Press Start to begin your workout.

XTERRA TREADMILL PROFILES (TR450/TR550)

SPEED PROFILE

INCLINE PROFILE

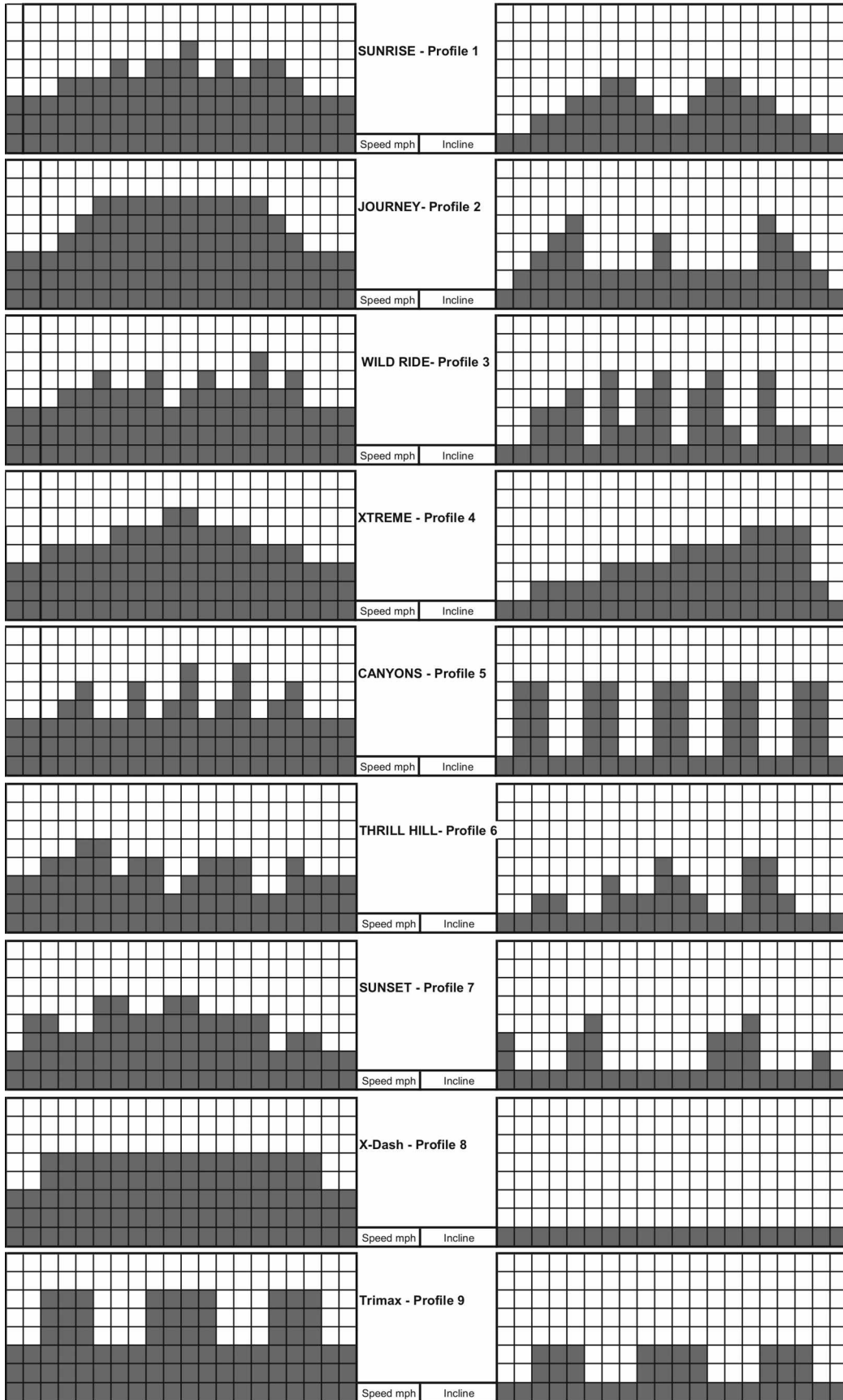

User Programs:

STEP 1: Select User 1 or User 2 via the **PROGRAM** key then press **Enter**. Note that the dot matrix display portion will have a single row of dots at the bottom (Unless there is a previously stored program).

STEP 2: Note the Time window is flashing. Use the **Adjust UP/DOWN** keys to adjust up from 10 minutes (if desired). Press **ENTER** key. This is a must to continue even if time is not adjusted.

STEP 3: The Calorie window will now be blinking a bodyweight value. Enter your bodyweight and press **Enter**.

STEP 4: The Calorie window will now be blinking an Age value. Adjust the age and press enter.

STEP 5: The first column (segment) will now be blinking. Using the **Fast / Slow or rapid** keys, adjust the speed level to your desired effort for the first segment then press enter. The second column will now be blinking. Repeat the above process until all segments have been programmed. The first column will be blinking again. This is for the incline programming. Repeat the above process to program all segments for incline.

STEP 6: Press the **Start** button to begin the workout and also save the program to memory.

Heart Rate Control Operation

How the Heart Rate Control Program Works:

Heart Rate Control uses your treadmill's incline system to adjust your heart rate. Increases and decreases in elevation affect heart rate much more efficiently than changes in speed. Additionally, changes in incline keep you in control of the machine's speed instead of the machine controlling you.

Selecting a Heart Rate Control Program:

You have the option, during the setup mode, to choose either the Weight Control (H-1) program or the Cardiovascular (H-2) program. The Weight Control program attempts to maintain your heart rate at 70% of your Maximum Heart Rate. The Cardiovascular program attempts to maintain your heart rate at 90% of your Maximum Heart Rate. Your Maximum Heart Rate is based upon a formula that subtracts your age from 220. Your age input is performed during the setup mode.

CAUTION!

The target value used in H-1 and H-2 programs is a suggestion only for normal, healthy individuals. Do not exceed your limits! You may not be able to obtain your chosen target. If in question, enter a higher age value that will set a lower target goal.

STEP 1: Press the Program up/down keys to select the HR1 or HR2 program.

STEP 2: The Calorie window will now be blinking bodyweight. Adjust and press enter or press enter to accept default.

STEP 3: The Calorie will now be blinking showing age. Adjust and press enter or press enter to accept default.

STEP 4: The Calorie window will now be blinking showing the THR (Target Heart Rate). You can now adjust it or press enter to accept the default.

STEP 5: The Time window will now be blinking. Adjust the time and press enter.

STEP 6: Press Start to begin program.

*Remember that you must maintain contact with the sensors for the program to work.

General Maintenance

Belt and Bed - Your treadmill uses a very high-efficient low-friction bed. Performance is maximized when the bed is kept as clean as possible. Use a soft, damp cloth or paper towel to wipe the edge of the belt and the area between the belt edge and frame. Also reach as far as practical directly under the belt edge. This should be done once a month to extend belt and bed life. Use water only - no cleaners or abrasives. A mild soap and water solution along with a nylon scrub brush will clean the top of the textured belt. **Allow the belt to dry before using.**

Belt Dust - This occurs during normal break-in or until the belt stabilizes. Wiping excess off with a damp cloth will minimize buildup.

General Cleaning - Dirt, dust, and pet hair can block air inlets and accumulate on the running belt. On a monthly basis: vacuum underneath your treadmill to prevent buildup. Once a year, you should remove the black motor hood and vacuum out dirt that may accumulate. **UNPLUG POWER CORD BEFORE THIS TASK.**

BELT ADJUSTMENTS:

Tread-belt Tension Adjustment - Belt tension is not critical for most users. It is very important for joggers and runners in order to provide a smooth, steady running surface. Adjustment must be made from the right side of the rear roller in order to adjust tension with the 6 mm Allen wrench provided in the parts package. The adjustment bolt is located at the end of the right side rail as noted in diagram below.

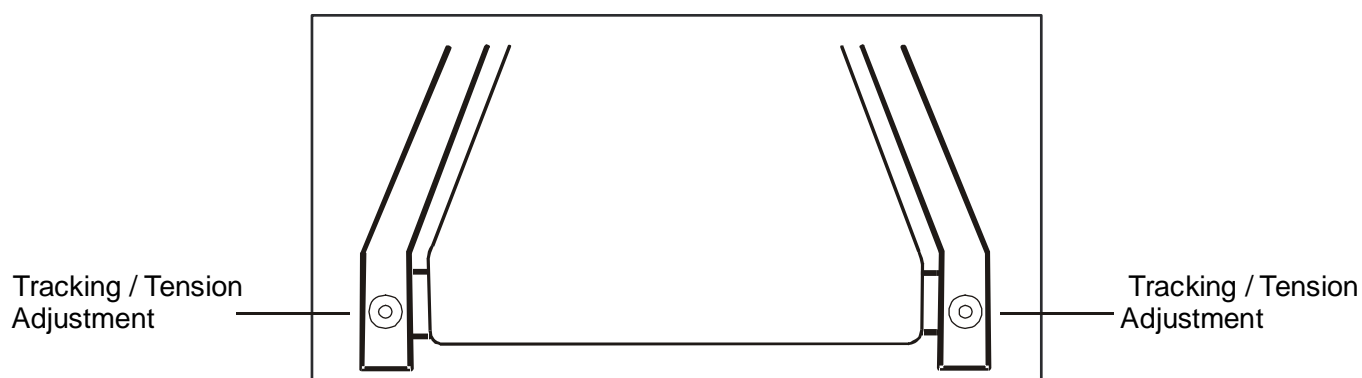

Note: Adjustment is through small hole in end

Tighten the rear roller only enough to prevent slippage at the front roller. Turn the tread-belt tension adjustment bolt in increments of 1/4 turn and inspect for proper tension.

When an adjustment is made to the belt tension, you must also make a tracking adjustment to compensate for the change in belt tension. This is accomplished by turning both the tension and tracking Allen bolts an equal amount. This adjustment is accomplished by turning both bolts clockwise no more than a 1/4 turn at a time.

DO NOT OVERTIGHTEN – Over tightening will cause belt damage and premature bearing failure.

TREADBELT TRACKING ADJUSTMENT:

The performance of your treadmill is dependent on the frame running on a reasonably level surface. If the frame is not level, the front and back roller cannot run parallel, and constant belt adjustment may be necessary.

The treadmill is designed to keep the tread-belt reasonably centered while in use. It is normal for some belts to drift near one side while the belt is running with no one on it. After a few minutes of use, the tread-belt should have a tendency to center itself. If, during use, the belt continues to move toward one side, adjustments are necessary.

TO SET TREADBELT TRACKING:

A 6 mm Allen wrench is provided to adjust the rear roller. Make tracking adjustments from the **left** side only. Set belt speed at

approximately 2 to 3 mph. A small adjustment can make a dramatic difference. Turn the bolt only a 1/4 turn and wait a few minutes for the belt to adjust itself.

Continue to make 1/4 rotation turns until the belt stabilizes in the center of the running deck. The belt may require periodic tracking adjustment depending on use and walking/running characteristics.

Some users will affect tracking differently.

Expect to make adjustments as required to center the tread-belt. Adjustments will become less of a maintenance concern as the belt is used. Proper belt tracking is an owner responsibility common with all treadmills.

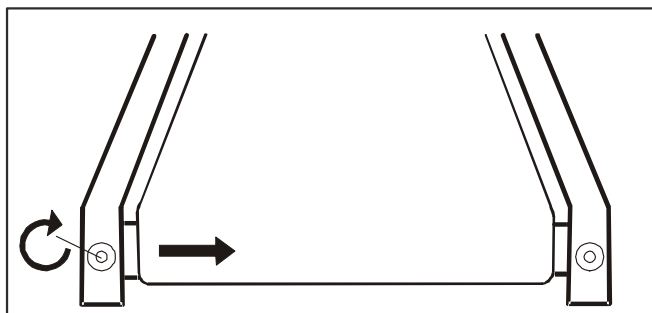

ATTENTION:

DAMAGE TO THE RUNNING BELT RESULTING FROM IMPROPER TRACKING / TENSION ADJUSTMENTS IS NOT COVERED UNDER THE XTERRA WARRANTY.

MAINTENANCE MODE:

If you want to set the Speed and Distance to Metric or if there is a problem with the speed and you would like to perform the calibration procedure, use the Maintenance Mode. To enter Maintenance Mode press, and hold for 5 seconds, the Start and Fast keys while installing the safety key. All the segments will light then the message window will display software versions and tell you to press Enter.

- The message window will now be showing the setting for English (miles) or Metric (Kilometers) Use the up/down keys to select and press enter
- The message window will ask to adjust the.Wheel size for calibration. Enter 2.83.
- The display will show a number for the lowest speed setting (for miles the number should be 0.5). Adjust the low speed setting with the Fast/Slow keys and press Enter.
- The display will show a number for the top speed setting (for Miles it should be 12.0).
- The display will ask for top incline setting, enter 12 for TR450 and 15 for TR550.
- The display will ask for grade return. This will reset the incline to zero, when set to ON, when you stop a program.
- Press Start to begin calibration. This is an automatic process, the belt will move and change speeds without warning, Be Careful! When calibration is done, the console will return to the start-up screen.

BELT / DECK LUBRICATION:

Do not lubricate with other than Xterra approved lubricant. Your treadmill comes with one tube of lubricant and extra tubes can be ordered directly from Xterra. There are commercially available lube kits, but the only one currently approved by Xterra is Lube-N-Walk. These kits come with an application wand that makes applying the lubrication easier. The kits can be purchased from Xterra or directly from Lube-N-Walk here: <http://www.jadfitness.com/> When ordering make sure to specify silicone lubricating kit, not paraffin wax.

Keeping the deck lubricated at the recommended intervals ensures the longest life possible for your treadmill. If the lubricant dries out, the friction between the belt and deck rises and places undue stress on the drive motor, drive belt and electronic motor control board, which could result in catastrophic failure of these expensive components. Failure to lubricate the deck at regular intervals may void the warranty.

The deck comes pre-lubricated and subsequent lubrication should be performed every 180 hours of use. The console has a built in lubrication reminder indicator that lights every 180 hours of use. To lubricate the deck with the tube of lubricant supplied it will be necessary to loosen the walking belt. Using the 6 mm allen wrench supplied, loosen the two rear roller adjustment bolts -- located in the rear end caps -- enough to get your hand under the belt (5 –10 turns). Make sure to loosen both bolts the same amount of turns and also remember how many turns, because when finished you will need to tighten the bolts back to the point they were before.

Once the belt is loose, wipe the deck with a clean lint free cloth to remove any dirt. Apply the whole tube of lubricant onto the deck surface about 18 inches from the motor cover. Squeeze out the contents of the tube across the deck (parallel to the motor cover) in about a one-foot long line, like toothpaste on a toothbrush. The one-foot line should be in the middle of the deck at approximately equal distance from both side edges of the belt. You want the lubricant to be applied about the spot that your feet would hit the belt as you are walking. This should be about 18 inches from the motor cover, but you may want to walk on the treadmill before loosening the belt to note where your feet land on the belt. If you mostly run on the treadmill, the spot where your feet land may be different from walking.

Once the lubricant is applied, tighten the rear roller bolts the same amount of turns as when you loosened them. Run the treadmill at about 6 mph without walking on it for about a minute or two to make sure the belt stays in the middle of the deck. If the belt tracks to one side then follow the belt tracking instructions to remedy. Now the deck is lubricated and you should walk, not run, on the treadmill immediately for at least 5 minutes to ensure the lubricant is evenly distributed. If you purchase a Lube-N-Walk kit, follow the instructions that come with it to apply the lubrication.

Service Checklist - Diagnosis Guide

Before contacting your dealer for aid, please review the following information. It may save you both time and expense. This list includes common problems that may not be covered under the treadmill's warranty.

PROBLEM	SOLUTION/CAUSE
Display does not light	Tether cord not in position. Circuit breaker on front grill tripped. Push circuit breaker in until it locks. Plug is disconnected. Make sure plug is firmly pushed into the AC household wall outlet. Household circuit breaker may be tripped. Treadmill defect. Contact your Xterra dealer.
Treadmill belt does not stay centered Treadmill belt hesitates when walked/run on	A user may be walking while favoring or putting more weight on either the left or right foot. If this walking pattern is natural, track the belt slightly off-center to the side opposite from the belt movement. See General Maintenance section on Treadmill belt Tension. Adjust as necessary.
Motor is not responsive / Display is lit	Make certain clock is running. If it is then service may be Needed.
Treadmill will only achieve approximately 7 mph but shows higher speed on display	This indicates motor should be receiving power to operate. Low AC voltage to treadmill. Do not use an extension cord. If an extension cord is required it should be as short as possible and heavy duty 16 gauge minimum. Low household voltage. Contact an electrician or your Xterra dealer. A minimum of 110 volt AC current is required.
Treadmill belt stops quickly/suddenly when tether cord is pulled	High belt/deck friction. See General Maintenance section on lubrication.
Treadmill trips on board 15 amp circuit	High belt/deck friction. See Belt/deck lubrication procedure
Computer shuts off when console is touched (on a cold day)while walking/running	Treadmill is not grounded. Static electricity is "crashing" the computer. Refer to Grounding Instructions on page 4.

ERROR MESSAGES:

- LS:** The treadmill hasn't received a speed signal for 8 seconds.
- E1:** Console memory malfunction or CPU problem.
- E2:** Incline position error

Manufacturer's Limited Warranty

Effective July 15, 2009 TREADMILL LIMITED WARRANTY

Xterra Fitness Inc. warrants all its home use treadmill parts for a period of time listed below, from the date of retail sale, as determined by a sales receipt or in the absence of a sales receipt, eighteen (18) months from the original factory shipping date. Xterra's responsibilities include providing new or remanufactured parts, at Xterra's option, and technical support to our independent dealers and servicing organizations. In the absence of a dealer or service organization, these warranties will be administered by Xterra Fitness directly to a consumer. The warranty period applies to the following components:

Home Use Limited WARRANTY

Frame and Motor	Lifetime
Deck	3 Years (5 years for TR550)
Parts	1 Year (2 Years for TR550)
Labor	1 Year

NORMAL RESPONSIBILITIES OF THE CONSUMER

This warranty applies only to products in ordinary household use. The consumer is responsible for the items listed below:

1. The warranty registration card must be completed and returned to the address listed on the card within 10 days of the original purchase to validate the manufacturer's limited warranty or register online at www.xterrafitness.com
2. Proper use of the treadmill in accordance with the instructions provided in this manual, including maintenance.
3. Proper connection to a power supply of sufficient voltage, replacement of blown fuses, repair of loose connections or defects in house/facility wiring.
4. Expenses for making the treadmill accessible for servicing, including any item that was not part of the treadmill at the time it was shipped from the factory.
5. Damages to the treadmill finish during shipping, installation or following installation.

EXCLUSIONS

This warranty does not cover the following:

1. CONSEQUENTIAL, COLLATERAL, OR INCIDENTAL DAMAGES SUCH AS PROPERTY DAMAGE AND INCIDENTAL EXPENSES RESULTING FROM ANY BREACH OF THIS WRITTEN OR ANY IMPLIED WARRANTY.

Note: Some states do not allow the exclusion or limitation of incidental or consequential damages, so this limitation or exclusion may not apply to you.

2. Service call reimbursement to the consumer. Service call reimbursement to the dealer that does not involve malfunction or defects in workmanship or material, for units that are beyond the warranty period, for units that are beyond the service call reimbursement period, for treadmills not requiring component replacement, or treadmills not in ordinary household use.
3. Damages caused by services performed by persons other than authorized Xterra Fitness service companies, use of parts other than original Xterra parts, or external causes such as alterations, modifications, abuse, misuse, accident, improper maintenance, inadequate power supply, or acts of God.
4. Products with original serial numbers that have been removed or altered.
5. Products that have been; sold, transferred, bartered, or given to a third party.
6. Products that are used as store display models.
7. Products that do not have a warranty registration on file at Xterra Fitness, inc. Xterra Fitness reserve the right to request proof of purchase if no warranty record exists for the product.
8. THIS WARRANTY IS EXPRESSLY IN LIEU OF ALL OTHER WARRANTIES EXPRESSED OR IMPLIED, INCLUDING THE WARRANTIES OF MERCHANTABILITY AND/OR FITNESS FOR A PARTICULAR PURPOSE.

SERVICE

Keep your bill of sale. Twelve (12) months from the date on the bill of sale or eighteen (18) months from the date of factory shipping as determined by the serial number establishes the warranty period should service be required. If service is performed, it is in your best interest to obtain and keep all receipts. This written warranty gives you specific legal rights. You may also have other rights that vary from state to state. Service under this warranty must be obtained by following these steps, in order:

1. Contact your selling authorized Xterra Fitness dealer. OR
2. Contact your local authorized Xterra Fitness service organization.
3. If there is a question as to where to obtain service, contact our service department at (870) 935-1107.
4. Xterra's obligation under this warranty is limited to repairing or replacing, at Xterra's option, the product through one of our authorized service centers. All repairs must be preauthorized by Xterra. If the product is shipped to a service center freight charges to and from the service center will be the customer's responsibility. For replacement parts shipped while the product is under warranty, the customer will be responsible for shipping and handling charges. For in-home service, the customer will be responsible for a trip charge. There will be an additional trip charge if the customer is located over 100 miles from the nearest service center.
5. The owner is responsible for adequate packaging upon return to Xterra. Xterra is not responsible for damages in shipping. Make all freight damage claims with the appropriate freight carrier. DO NOT SHIP ANY UNIT TO OUR FACTORY WITHOUT A RETURN AUTHORIZATION NUMBER. All units arriving without a return authorization number will be refused.
6. For any further information, or to contact our service department by mail, send your correspondence to:

Xterra Fitness, Inc.
P.O. Box 2037
Jonesboro, AR 72402-2037

Product features or specifications as described or illustrated are subject to change without notice. All warranties are made by Xterra Fitness, Inc. This warranty applies only in the 50 states of the U.S.A.